



**MISSOURI DEPARTMENT OF TRANSPORTATION  
MATERIALS ENGINEERING  
Jefferson City, Missouri**

**Test Method  
MoDOT T59  
DETERMINATION OF THE PROFILOGRAPH INDEX**

**1.0 SCOPE.** This method describes the procedure for determining the profilograph index of portland cement concrete pavement and asphaltic concrete surfaces.

**1.1** This method is for determination of profilogram index in english units only, not metric.

**2.0 APPARATUS.** The profilograph shall consist of a frame twenty-five feet in length supported upon wheels at either end. The profile shall be recorded from the vertical movement of a wheel attached to the frame at mid-point and in reference to the mean elevation of the points of contact with the road surface established by the support wheels (see Figure 1).

**2.1** The profilogram shall be recorded on a scale of one inch equal to twenty-five feet longitudinally and one inch equal to one inch, or full scale, vertically.

**2.2** Motive power may be provided manually or by use of a propulsion unit powered with a gasoline engine using the manufacturer's towing option. In operation, the profilograph should be moved at a speed no greater than a walk (about 4.5 mph) (Excessive speed will increase the profilograph index count.)

**2.3** Calibration of the profilograph shall be checked periodically. The horizontal scale is checked by running a known distance and scaling the result on the profilogram. If the scale is off, the profilograph should be recalibrated. The vertical scale is checked by putting a calibration block of known thickness under the profile wheel and again scaling the result on the profilogram. If the scale is off, the cause of the incorrect height should be determined and corrected.

**3.0 PROCEDURE.**

**3.1 Automated Profilogram Evaluation.** Automated profilogram evaluation will be used unless otherwise determined by the engineer.

**3.1.1** The engineer's profilogram from calibration test sections and assurance testing will be evaluated using automated trace reduction performed by an automated Ames unit with the following settings:

- a) Filter length: Low Pass = 3 to 4 (ft.), High Pass = 0.00 (ft.)



Filter length has the same effect as using the contrasting color to outline the trace, removing spikes and high frequency chatter.

- b) Scallop rounding = 0.01 inches

This setting determines the amount of rounding given to any particular scallop. For example: In order to measure a defect to the nearest 0.05 inch, the rounding on the machine must be set higher (finer) to accurately make that determination.

- c) Minimum Scallop height = 0.030 inches (in software, non-adjustable)

Minimum Scallop Width = 0.08 inches (in software, non-adjustable)

Scallop height and width corresponds to existing standards. .08 inches is equal to 2 feet on the roadway. 0.030 inches simply provides a means to count a defect that is more than 0.030 inches tall as 0.05.

- d) Template height for grind point = 0.4 inches

Corresponds to the standard bump template.

- e) Bump Width = 25 feet

- f) Band Width = 0.001 inches

**3.2 Manual Profilogram Evaluation.** To determine the profile index, use a transparent scale 1.70 inches wide and 21.12 inches long representing a pavement length of 528 feet or one-tenth of a mile at a scale of 1 inch = 25 feet. Near the center of the scale is a dashed reference line extending the entire length of 21.12 inches. On either side of this dashed reference line are scribed lines 0.1 inch apart. These lines serve as a convenient scale to measure deviations or excursions of the graph above or below the dashed reference line. These are called “scallops” .

**3.3 Method of Counting.** Place the transparent scale over the profile in such a way as to center it on the profile as much as possible. When this is done, scallops above and below the dashed reference line usually will be approximately balanced. See Figure 2.

**3.3.1** The profile trace will move from a generally horizontal position when going around super elevated curves making it impossible to center the trace without shifting the scale. When such conditions occur the profile should be broken into short sections and the dashed reference line repositioned on each section while counting as shown in the upper part of Figure 3.

**3.3.2** Short portions of the profile line may be visible above or below the dashed reference line but unless they project 0.03 inch or more and extend longitudinally for two feet (0.08 inches on the profilogram) or more, they are not included in the count. (See Figure 2 for illustration of these special conditions.) Starting at the right end of the scale, measure and total the height of all the scallops appearing both above and below the



dashed reference line, measuring each scallop to the nearest 0.05 inch (half a tenth). Record this total on the profile sheet near the left end of the scale together with a small mark to align the scale when moving to the next section.

**3.3.3** When scallops occurring in the first 0.1 mile are totaled, slide the scale to the left, aligning the right end of the scale with the small mark previously made, and proceed with the counting in the same manner. The last section counted may or may not be an even 0.1 mile. If not, its length should be scaled to determine its length in miles. An example is as follows:

	<u>Section length, Miles</u>	<u>Counts, inches</u>
	0.10	.50
	0.10	.40
	0.10	.35
	<u>0.076</u>	<u>.20</u>
400 feet = Total	0.376	1.45

**3.3.3.1** The procedure for converting counts of profile index is as follows:  
 Using the figures from the above example:

$$\text{Profile Index} = (1.45 \text{ in.}) / (0.376 \text{ miles}) = 3.9 \text{ inches/mile}$$

**3.4 Limits of Counts - - Joints.** When counting profiles, a day' s paving is considered to include the last portion of the previous day' s work, which includes the daily joint. The last 15 to 30 feet of a day' s paving cannot usually be obtained until the following day. In general, the paving contractor is responsible for the smoothness of joints if pavement is placed on both sides of the joint. On the other hand, the contractor is responsible only for the pavement placed if the work abuts a bridge or a pavement placed under another contract. Profilograph readings when approaching such joints should be taken in accordance with the standard specifications.

**3.5 Average Profile Index for a Section.** When averaging profile indexes to obtain an average for a section, the average for each segment must be "weighted" according to its length. (See Figure 4 and 5.) Figure 4 is an example when the last segment is longer than 250 feet and Figure 5 is an example when the last segment is less than 250 feet).

**3.6 Determination of High Points in excess of 0.4 inch.** Use a transparent bump template having a line one inch long scribed on one face with a small hole or scribed mark at either end, and a slot 0.4 inch from and parallel to the scribed line. See Figure 3. (The one inch line corresponds to a horizontal distance of 25 feet on the horizontal scale of the profilogram).

**3.7 Locating High Points in Excess of 0.4 inch.** At each prominent peak or high point on the profile trace, place the template so that the small holes or scribe marks at each end of the scribed end of the scribed line intersect the profile trace to form a chord across the base of the peak or indicated bump. The line on the template need not be horizontal. With a sharp pencil draw a line using the narrow slot in the template as a guide. Any portion of the trace extending above this line will indicate the approximate length and height of the deviation in excess of 0.4 inch.



**3.7.1** There may be instances where the distance between easily recognizable low points is less than one inch (25 feet). In such cases a shorter chord length shall be used in making the scribed line on the template tangent to the trace at the low points. It is the intent, however, of this requirement that the baseline for measuring the height of bumps will be as nearly 25 feet (1 inch) as possible, but in no case to exceed this value. When the distance between prominent low points is greater than 25 feet (1 inch) make the ends of the scribed line intersect the profile trace when the template is in a nearly horizontal position. A few examples of the procedure are shown in the lower portion of Figure 3.

**4.0 CERTIFIED OPERATOR.** The contractor shall furnish a certification stating that the test was performed by a trained operator. The operator must be certified as having been trained in the use of the profilograph and certified to have sufficient experience to demonstrate competence in the use of the equipment.

**5.0 QUALITY CONTROL/QUALITY ASSURANCE.** The contractor's quality control profilogram evaluation will be compared to the engineer's quality assurance profilogram evaluation on a test section established by MoDOT and on a randomly selected portion of the work, usually ten percent of the project length. Automated profilogram evaluation using an automated Ames unit as outlined in Sec 3.1 will be the engineer's basis for comparison.



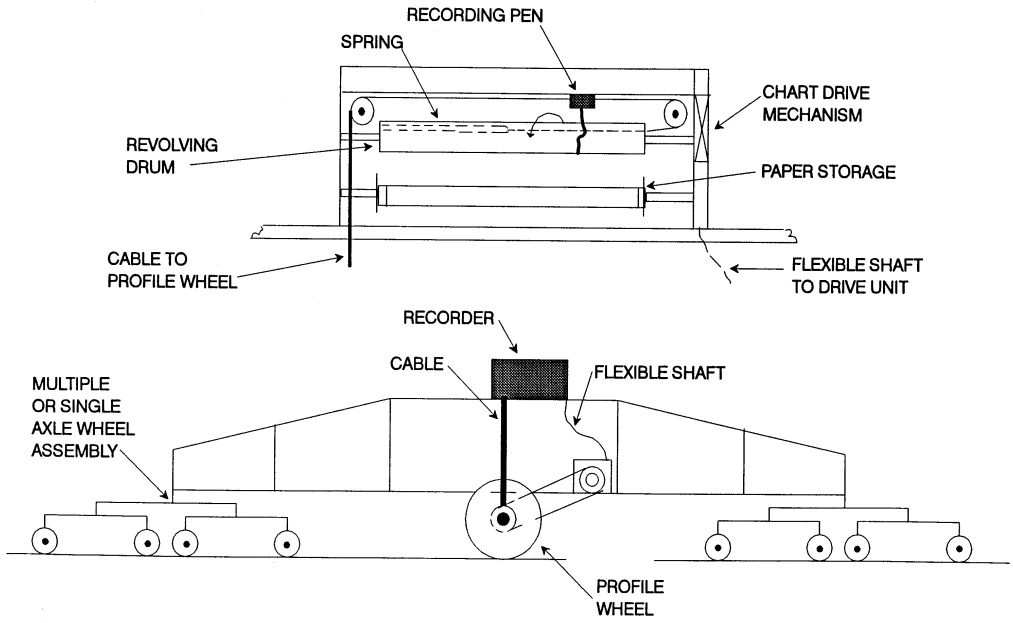
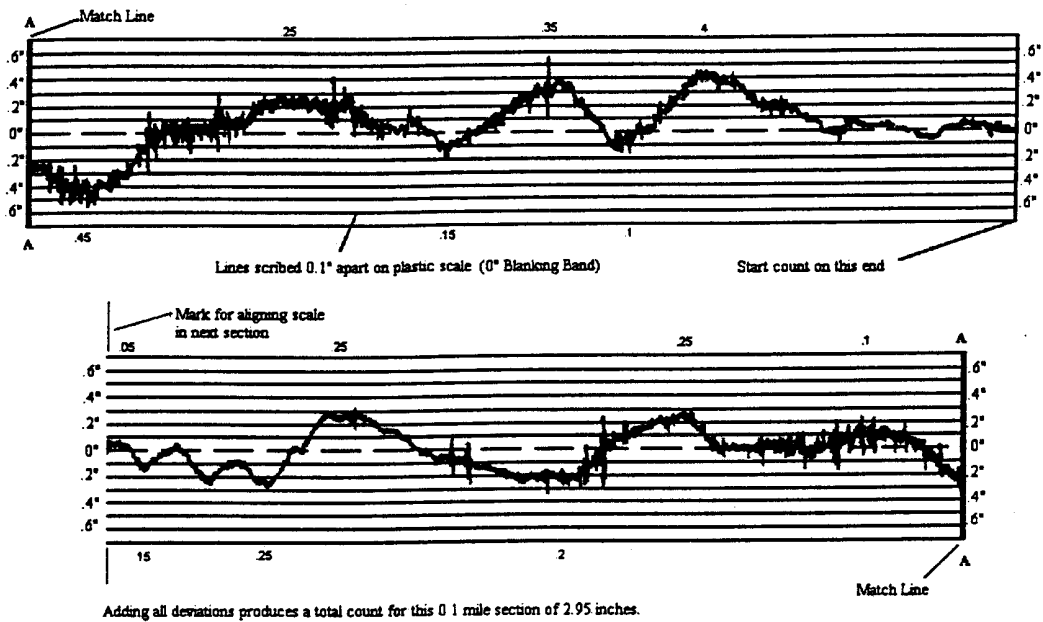
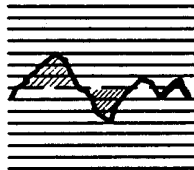

FIGURE 1



TYPICAL CONDITIONS

Scallops are areas enclosed by profile line and blanking band (Shown cross hatched below)



A

Only projections 0.3" in width and greater are included in the count. Small projections which are not included in the count

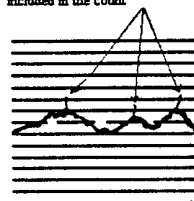

B

SPECIAL CONDITIONS

Rock or dirt on the pavement (not counted)

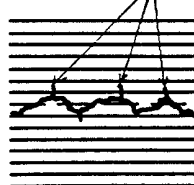

C

Double peaked scallop (Only highest part counted)

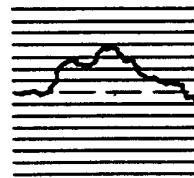

D

Figure 2

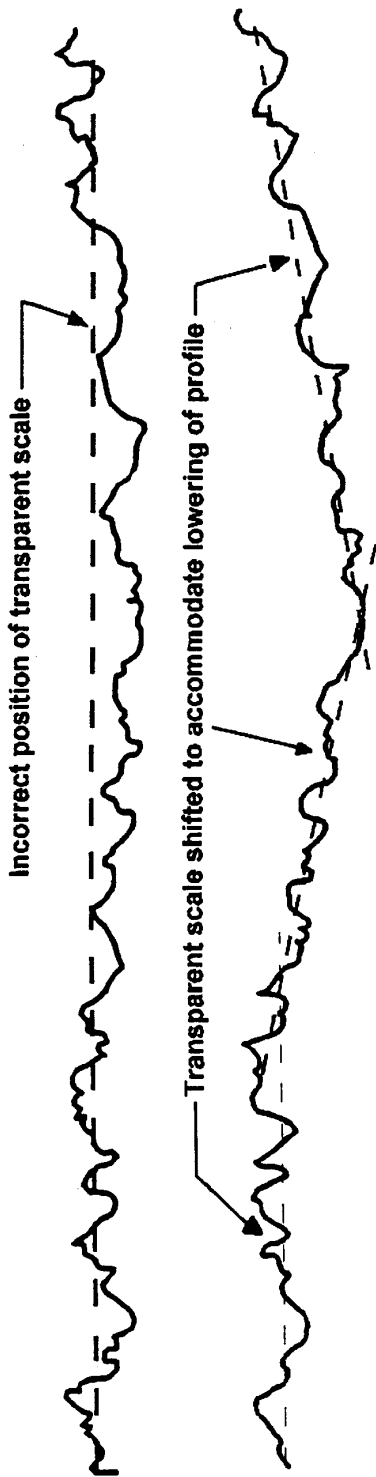

METHOD OF PLACING TEMPLATE WHEN LOCATING BUMPS TO BE REDUCED

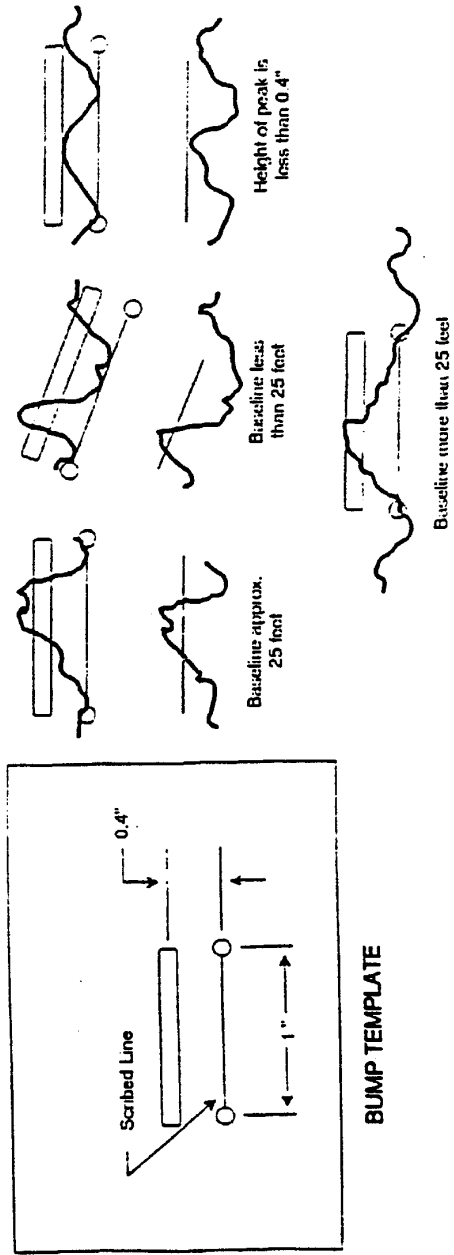

Figure 3

Missouri Department of Transportation  
 Profilograph Report on Pavement Smoothness

Report No.   2    
 \_\_\_\_\_ Information  
  X   Initial  
 \_\_\_\_\_ Intermediate  
 \_\_\_\_\_ Final  
  X   AC    PCCP

Route   63   Project No.   F-63-3(101)    
 County   Boone   Job No.   J3P123486    
 Prime Contractor   T.A. Chance, Inc.    
 Paving Subcontractor   S & S Paving Company    
 Station   153+00   to Station   173+28   Traffic Direction   EB    
 No. of Lanes   1   Direction of Paving   EB    
 Date Paved (corrected)   7-7-97   Date Tested   7-8-97    
 Evaluated by   Alan Jones   Title   SCI  

Length (miles)	Track 1 Measured Roughness Inches	Track 1 Profile Index (in/mi)	Track 2 Measured Roughness (inches)	Track 2 Profile Index (in/mi)	Track 3 Measured Roughness (inches)	Track 3 Profile Index (in/mi)	Average Profile Index (in/mi)
.1	0.84	8.4 (1)					
0.1	0.91	9.1					
0.1	1.35	13.5					
<u>0.084 (5)</u>	<u>4.03</u>	<u>48.0 (2)</u>					
0.384	7.13 (3)	18.6 (4)					

Bump Locations   153 + 7    
 Section Profile Index   18.6 in/mi (4)    
 Length   2,028   feet  
 Deduction   444 ft (6)   tons  
 Bonus   None   tons

Distribution: Construction Engineering  
 District Office  
 Project Office

-----  
 (1)  $\frac{0.84}{0.1} = 8.4$       (2)  $\frac{4.03}{0.084} = 48.0$       (3)  $0.84 + 0.91 + 1.35 + 4.03 = 7.13$       (4)  $\frac{7.13}{0.384} = 18.6$

(5) Where last segment is **more than** 250 feet.      (6)  $0.084 \times 5280 = 444$

Figure 4



Missouri Department of Transportation  
 Profilograph Report on Pavement Smoothness

Report No. 2  
 \_\_\_\_\_ Information  
X Initial  
 \_\_\_\_\_ Intermediate  
 \_\_\_\_\_ Final  
X AC \_\_\_ PCCP

Route 63 Project No. F-63-3(101)  
 County Boone Job No. J3P123486  
 Prime Contractor T.A. Chance, Inc.  
 Paving Subcontractor S & S Paving Company  
 Station 173+28 to Station 196+41 Traffic Direction EB  
 No. of Lanes 1 Direction of Paving EB  
 Date Paved (corrected) 7-8-97 Date Tested 7-9-97  
 Evaluated by Eve Smith Title SCI

Length (miles)	Track 1 Measured Roughness (inches)	Track 1 Profile Index (in/mi)	Track 2 Measured Roughness (inches)	Track 2 Profile Index (in/mi)	Track 3 Measured Roughness (inches)	Track 3 Profile Index (in/mi)	Average Profile Index (in/mi)
0.1	2.35	23.5 (1)					
0.1	1.97	19.7					
0.1	2.22	22.2					
<u>0.138 (5)</u>	<u>6.49</u>	<u>47.0 (2)</u>					
0.438	13.03 (3)	29.7 (4)					

Bump Locations 175 + 92 196 + 38  
 Section Profile Index 29.7 in/mi (4)  
 Length 2,313 feet  
 Deduction 729 ft (6) tons  
 Bonus None tons

Distribution: Construction Engineering  
 District Office  
 Project Office

-----  
 (1)  $\frac{2.35}{0.1} = 23.5$       (2)  $\frac{6.49}{0.138} = 47.0$       (3)  $2.35 + 1.97 + 2.22 + 6.49 = 13.03$       (4)  $\frac{13.03}{0.438} = 29.7$   
 0.438

(5) Where last segment is **less than** 250 feet.      (6)  $0.138 \times 5280 = 729$

Figure 5

